

REVISIONS			
SYM	DESCRIPTION	BY	DATE
1	ORIGINAL	BJD	12/6/10
2	.197 dia was M5x0.8 Tapped	BJD	12/7/10
3	Length of hex was .268	BJD	12/15/10

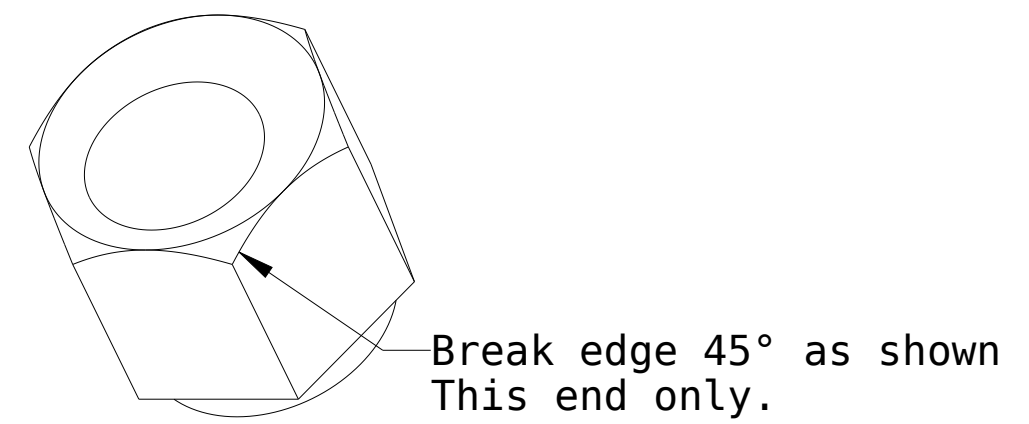

Notes:
1. All dimensions in inches unless otherwise indicated.

Material Table		
Part Number	Material:	Finish
B18001-001	Stainless Steel (Type 303)	None
B18001-002	Brass (Alloy 360)	None
B18001-003	Aluminum 6061	None

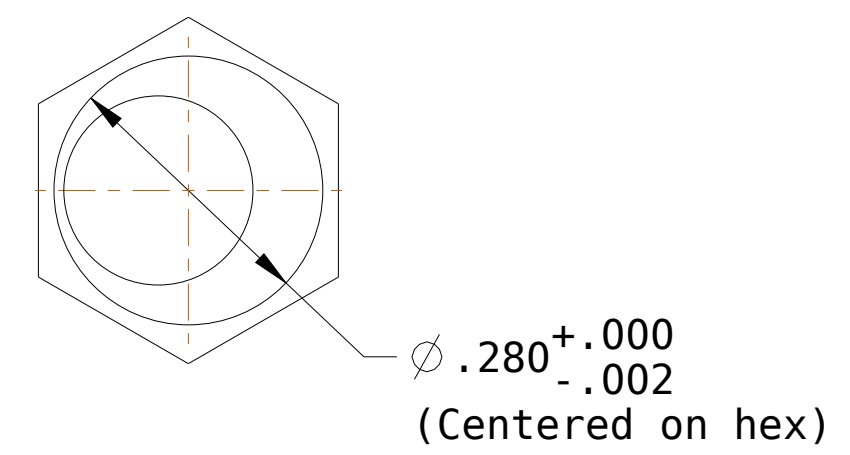
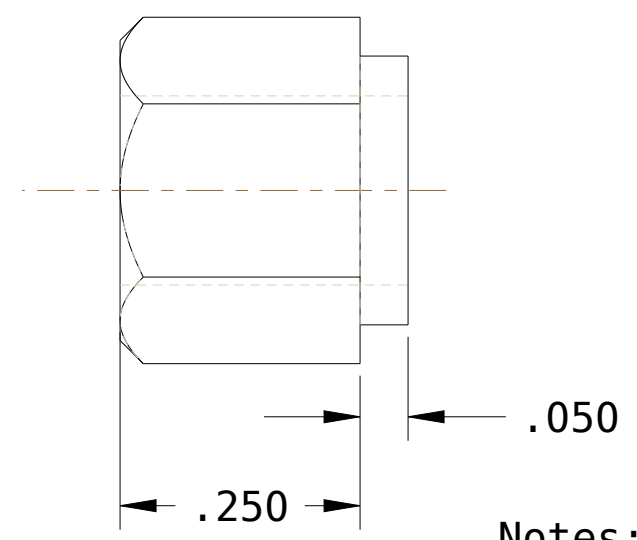
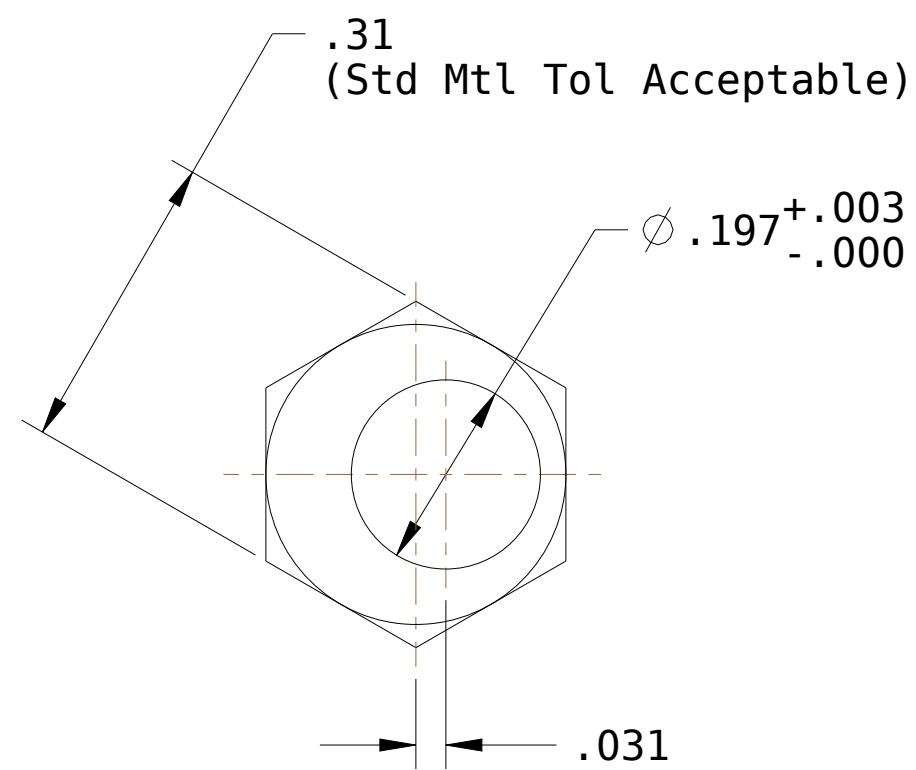

The work is licensed under a Creative Commons Attribution-Share Alike 3.0 License

DRAWN	BJD	12/6/10
CHECKER		
MECH. ENGR.		
ELEC. ENGR.		
PROJ. ENGR.		
CHIEF ENGR.		

ECCENTRIC SPACER

SCALE



www.buildlog.net

B18001-TAB

SHEET 1 OF 1